

5024-S SPRING APPLIED BRAKE CALIPER

The model 5024-S brake caliper is a very compact and high torque brake caliper. It is basically of the same design as Model 5027 but only employs one actuator. All parts are interchangeable with Model 5027 except for the lever and brake shoe. The spring applied actuator provides very accurate control over the brake torque. Maximum torque is achieved with minimum fluid pressure.

It is important to keep the clearance between the disc and brake shoes at an absolute minimum in order to maintain maximum torque. Minimum clearance also means fast response. The actuator clevises can be adjusted to compensate for lining wear. In cycling applications, a tremendous amount of fluid medium can be saved with a shorter stroke of the actuator piston.

Our standard 2 x 4 disc series are suitable with this caliper for optimum energy absorption.

Specifications

Clamping force	25740 lbs.	(11673 kg.)
Max. disc thickness	2.0 in.	(51 mm)
Req. disc face	4 in.	(102 mm)
Total lining area	75 sq. in.	(483 sq. cm)
Lining thickness	0.625 in.	(15.8 mm)
Max. allowable lining wear	0.42 in.	(10.6 mm)
Average wear rate	0.005 cu. in./HP-hr	(0.082 cu. cm/HP-hr)
Coefficient of friction	0.45 at 68°F	(20°C)
Coefficient of friction	0.55 at 500°F	(260°C)
Max. release pressure	120 psi	(8.3 bar)
Max. pressure	250 psi	(17 bar)
Actuator volume	48 cu. in.	(787 cu. cm)
Weight	108 lb.	(49 kg)
Materials	Die cast silicon bronze with stainless steel hardware	

Ordering Information

5024-S	Spring Applied Brake Caliper
5024-SR	Spring Applied Brake Caliper with manual release screw

Important: Use only hydraulic fluid or air. Standard seals are not compatible with brake fluid.

When ordering brake calipers for discs smaller than the standard thickness, shim kits are available for adjustment. Add the last four digits of the appropriate kit to the code when ordering. Example: 5024-S1000 is for a 5024-S brake caliper set for 1" thick disc.

STANDARD VENTILATED KOBELT DISC: 2.0 in. (51 mm)

Disc Dia.	18	20	25	30	35	40	45	50
inches	18	20	25	30	35	40	45	50
mm	457	508	635	762	889	1016	1143	1270
Actg. Rad								
ft	0.58	0.67	0.88	1.08	1.29	1.50	1.71	1.92
meter	0.18	0.20	0.27	0.33	0.39	0.46	0.52	0.58
Torque								
ft-lb	7507	8580	11261	13942	16624	19305	21986	24668
kg-m	1038	1187	1557	1928	2299	2670	3041	3412
Maximum RPM	3070	2750	2200	1800	1550	1350	1200	1070

A variety of custom made disc are available. For discs smaller than the standard thickness, refer to the shim kit table below.

Disc thickness	Shim Kit Part number	Total shim size
1.50 in. (38.1mm)	5024-1500	0.50 in (13 mm) 1 shim (1/4") per side
1.00 in. (25.4mm)	5024-1000	1.00 in (25 mm) 1 shim (1/2") per side
0.50 in. (12.7mm)	5024-0500	1.50 in (38 mm) 1 each 1/4" & 1/2" shim per side

MODEL 5024-S

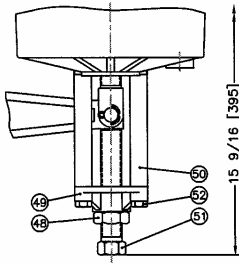
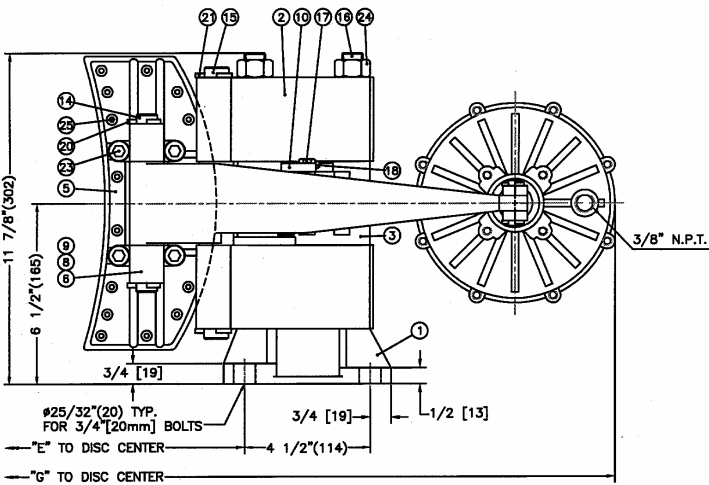
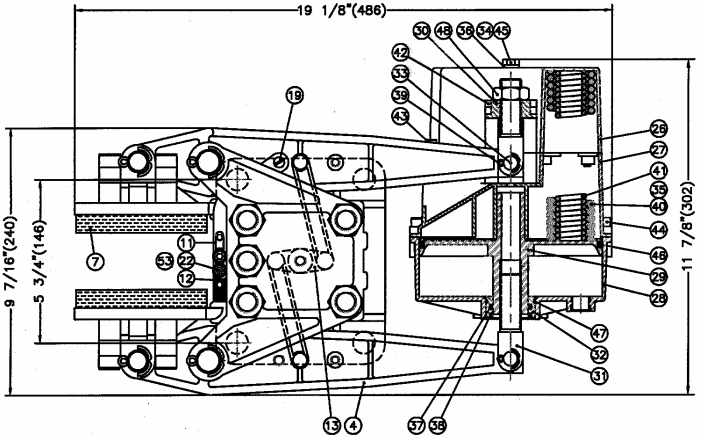

All dimensions in inches (mm)

Disc diam. inches	12	15	18	21	24	27	30
mm	305	381	457	533	610	686	762
Dim. "E" inches	7.25	8.75	10.25	11.75	13.25	14.75	16.25
mm	184	222	260	298	337	375	413
Dim. "G" inches	17.25	18.75	20.25	21.75	23.25	24.75	26.25
mm	438	476	514	552	591	629	687

Item	Qty	Part No.	Description
1	1	5024-0001	Foot
2	2	5024-0002	Saddle
3	1	5024-0003	Spacer
4	2	5024-0004	Lever
5	2	5024-0005	Shoe
6	4	5024-0006	Bearing
7	2	5024-0007	Lining
8	*	5024-0008	1/4" Shim
9	*	5024-0009	3/8" Shim
10	2	5024-0010	Connecting Link
11	2	5024-0011	Balancing Link No. 1
12	2	5024-0012	Balancing Link No. 2
13	1	5024-0019	Centre Pivot Link
14	2	5024-0021	Shoe Pin
15	2	5024-0022	Saddle Pin
16	5	5024-0023	Tie Rod
17	4	5024-0024	Shoulder Bolt
18	1	5024-0025	Shoulder Bolt
19	2	5024-0026	Link Pin
20	4	1026-0824	Cotter Pin
21	4	1026-1028	Cotter Pin
22	4	1002-1010	Socket Hd Cap Screw
23	8	1002-1420	Socket Hd Cap Screw
23	*	1002-1424	Socket Hd Cap Screw
23	*	1002-1432	Socket Hd Cap Screw
24	5	1022-0117	Hex Nut
25	40	1033-1007	Rivet
53	4	1023-0232	Flat Washer
		6230 Spring Applied Pot	
26	1	6230-0001	Spring Housing #1
27	1	6230-0101	Spring Housing #2
28	1	6230-0002	Piston Housing
29	1	6230-0003	Piston
30	1	6230-0004	Bracket
31	2	6230-0005	Clevis
32	1	6230-PHB	Bushing
33	2	6230-0010	Pin
34	2	6230-0011	Spring Guide
35	2	6230-0012	3/4 Spring Guide
36	2	1023-0311	Lock Washer
37	1	1102-3026	"U" Cup
38	1	6230-94013	Wiper
39	4	1026-0516	Cotter Pin
40	77*	1201-0158	Outer Spring
41	*7	1201-0159	Inner Spring
42	4	1002-1032	Socket Hd Cap Screw
43	8	1002-1012	Socket Hd Cap Screw
44	8	1002-1116	Socket Hd Cap Screw
45	2	1001-1116	Hex Head Screw
46	1	1101-1361	"O" Ring
47	1	1101-0030	"O" Ring
48	1	1022-0217	Jam Nut
		Manual Release Option	
49	1	6230-0006	Manual Release Bracket
50	4	6230-0007	Spacer
51	1	6230-0008	Release Screw
52	1	1001-1180	Hex Head Screw
48	1	1022-0217	Jam Nut

* Quantity may vary with options

Caution: When dismantling the actuator, it is important that it is retained in a press before the holding screws are removed.