

MODEL 5021-A FLUID APPLIED BRAKE CALIPER

The model 5021 brake caliper is very versatile because of its large shoe area and considerable clamping force. It is the main reason that it is used in virtually all industries where continuous braking and stopping is required.

The patented balancing lines ensure equal brake lining wear for both shoes and across the shoe itself. Shims can be installed between the brake shoe and bearing to reduce the clearance between the brake linings. This permits the caliper to be used with various disc thicknesses. The maximum disc thickness is two inches.

The actuator is equipped with two fluid supply ports. These ports are connected internally and in most cases, only one port will be connected to the pressure source. Varying the application pressure to the actuator causes an absolutely proportional change in the brake torque. It is for this reason that very sensitive braking control can be obtained. The maximum fluid supply is 100 psi (6.9 bar).

Standard brake discs are available (see Table I)

ORDERING INFORMATION

5021-A Fluid applied brake with standard foot

When ordering brake calipers for discs smaller than the standard thickness, add the last four digits of the appropriate shim kit to the part number. Example: 5021-A1250 is for 5021-A caliper set for 1¼" thick disc.

For discs thinner than the standard thickness, refer to the shim kit table below.

Max Disc thickness	Kit Part No.	Total shim size
1.50 in. (38.1 mm)	5021-1500	0.50 in. (12.7 mm) 1 shim (¼") per side
1.25 in. (31.8 mm)	5021-1250	0.75 in. (19 mm) 1 shim (3/8") per side
1.00 in. (25.4 mm)	5021-1000	1.00 in. (25.4 mm) 2 shims (¼") per side
0.75 in. (19 mm)	5021-0750	1.25 in. (31.8 mm) 2 shims (¼" & 3/8") per side
0.50 in. (12.7 mm)	5021-0500	1.50 in. (38.1 mm) 2 shims (3/8") per side

Specifications

Clamping force	9160 lbs	(4155 kg)
Max. disc thickness	2.0 in.	(51 mm)
Req. disc face	4 in.	(102 mm)
Total lining area	60 sq. in.	(387 sq. cm)
Lining thickness	0.5 in.	(12.7 mm)
Max. allowable lining wear	0.3 in.	(7.6 mm)
Average wear rate	0.005 cu. in./HP-hr	(0.082 c.c./HP-hr)
Coefficient of friction	0.45 at 68°F	(0.45 at 20°C)
Coefficient of friction	0.55 at 500°F	(0.55 at 260°C)
Maximum pressure	100 psi	(6.9 bar)
Actuator volume	30 cu. In.	(492 cu. cm)
Weight	53 lb.	(23.5 kg)
Material	Die cast silicon bronze with stainless steel hardware	

IMPORTANT: Use only hydraulic fluid or air.
Standard seals are NOT compatible with brake fluid.

Table I

KOBELT STANDARD VENTILATED DISCS: 2 in. (51 mm)

Disc Dia.	18	20	25	30	35	40	45	50
inches	18	20	25	30	35	40	45	50
mm	457	508	635	762	889	1016	1143	1270
Acting Rad.								
ft	.58	.67	.88	1.08	1.29	1.50	1.71	1.92
meter	.178	.203	.267	.330	.394	.457	.521	.584
Torque								
ft-lb	2660	3040	3990	4940	5890	6840	7790	8740
kg-m	368	420	552	682	814	945	1077	1208
Maximum RPM	3070	2750	2200	1800	1550	1350	1200	1070

Dimensions and Parts List Model 5021-A

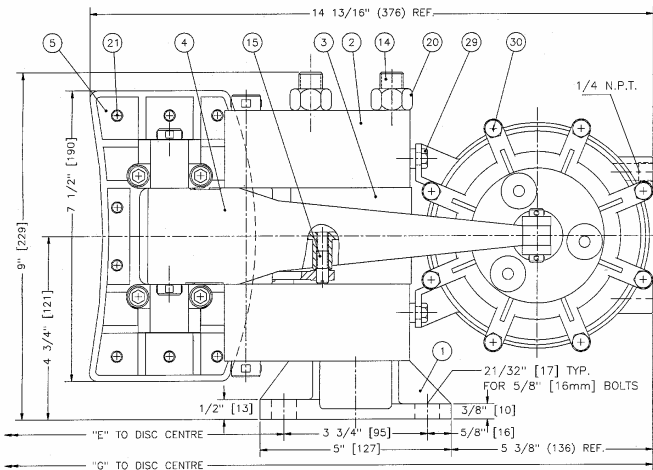
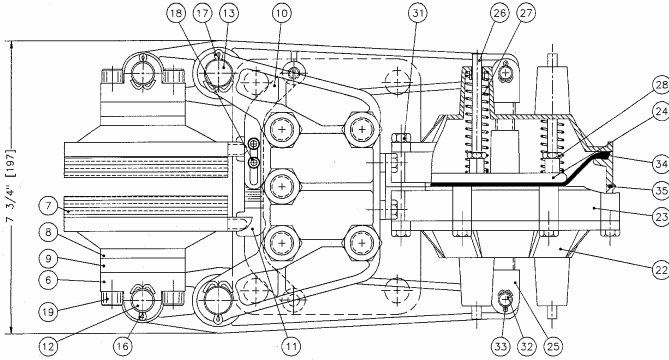

Item	Qty	Part No.	Description
1	1	5021-0001	Foot
2	2	5021-0002	Saddle
3	1	5021-0003	Spacer
4	2	5021-0004	Lever
5	2	5021-0005	Shoe
6	4	5022-0006	Bearing
7	2	5021-0007	Lining
8	*	5021-0008	1/4" Shim
9	*	5021-0009	3/8" Shim
10	2	5021-0011	Balancing Link No. 1
11	2	5021-0012	Balancing Link No. 2
12	2	5021-0021	Shoe Pin
13	2	5021-0022	Saddle Pin
14	5	5021-0023	Tie Rod
15	2	5021-0226	Link Pin
16	4	1026-0516	Cotter Pin
17	4	1026-0824	Cotter Pin
18	4	1002-0808	Socket Hd. Screw
19	8	1002-1216	Socket Hd. Cap Screw (standard)
19	*	1002-1220	Socket Hd. Cap Screw (-1500 shim kit)
19	*	1002-1224	Socket Hd. Cap Screw (-1250/1000 shim kit)
19	*	1002-1228	Socket Hd. Cap Screw (-0750/0500 shim kit)
20	5	1022-0116	Nut
21	24	1033-1007	Rivet
6112 Fluid Applied Pot			
22	2	6112-0001	End Cap
23	2	6112-0002	Centre Housing
24	2	6112-0003	Diaphragm Washer
25	2	6112-0005	Pot Clevis
26	6	6112-0007	Guide Pin
27	6	1201-0146	Spring
28	6	1022-0210	Jam Nut
29	4	1001-1008	Hex. Hd Screw
30	8	1001-1040	Hex. Hd Screw
31	8	1022-0110	Nut
32	2	6112-0010	Pin
33	4	1026-0312	Cotter Pin
34	2	1105-0012	Diaphragm
35	1	1101-0161	"O" Ring

* Quantity may vary

All dimensions in inches (mm)

Disc Diameter								
inches	18	20	25	30	35	40	45	50
mm	457	508	635	762	889	1016	1143	1270
Dimension "E"								
inches	9.75	10.75	13.25	15.75	18.25	20.75	23.25	25.75
mm	248	273	337	400	464	527	591	654
Dimension "G"								
inches	19.5	20.5	23.0	25.5	28.0	30.5	33.0	35.5
mm	495	521	584	648	711	775	838	902